®

Operators manual for Pentruder 6 – 10
Hydraulic wallsaw and Pentpak 15
Powerpack



Version: 1.2
Pentruder 6 – 10

Support &
Service document

99.12 – Manual 6-10 English 01.doc



Copyright © 1997 – 2000 Tractive AB.
Pentruder is a registered trade mark belonging to Tractive AB.

Contents

Introduction.....	2
Description of the machine.....	3
Saw head Pentruder 6 - 10 with accessories.....	3
Quick disconnect coupling for safe mounting of the saw blade	4
Tracks and brackets.....	5
Blade guard.....	6
Hydraulic Power Pack Pentpak 15.....	7
Safety precautions	8
Getting started	10
Preparations before commencing work.....	10
Preparation and mounting of track feet and tracks	11
Mounting the sawhead on the track (AND shifting gears)	13
Quick disconnect coupling for the saw blade	14
Peripheral cutting speed and spindle speed	17
Mounting the blade guard	18
Preparing the power pack	19
Word list.....	21
Maintenance.....	28
Technical data.....	30
Declaration of Conformity.....	32

Introduction

Thank you very much for your confidence in our product! You have chosen to invest in a product which will give you many years of efficient and profitable production. The Pentruder 6 – 10 has been developed based on more than 20 years of experience in this specialised field. With correct handling it offers outstanding performance, safety and reliability.

It is essential that all personnel working with, or in close proximity to, the saw have read and understood the contents of this manual before commencing operations. Only by reading and understanding the manual will the operator be able to take advantage of the many features and benefits of the Pentruder 6 – 10. We are confident that your investment in this equipment and its many design features will enhance your company's competitive edge and profitability!

The first section of this manual, page 1 – 2, contains the table of contents and an introduction of the machine.

The second section of this manual, page 3 – 9, contains a general description of the machine and explains the different features which make the Pentruder 6 – 10 to one of the safest and most efficient machines available on the market today.

The third section of this manual, page 10 – 20, contains a description how to get started with the machine. Please take careful note of the Safety Precautions.

The fourth section of this manual, page 21 – 27, is in the form of a word list, where information on operation and maintenance as well as on a particular item can be easily looked up.

The fifth section of this manual, page 28 – 31, contains instructions how to maintain the equipment, and technical data.

Important! *When you read this manual it is important that you read and understand what is said about safety under the headlines **"Important"**. In those paragraphs beginning with **"Important"** we inform about risks connected with use of the machine, and, if the safety precautions are not respected, can result in damage to property and persons in close proximity to the machine.*

Warning! *When you read this manual it is important that you read and understand what is said about safety under the headlines **"Warning"**. In those paragraphs beginning with **"Warning"** we inform about risks connected with use of the machine, and, if the safety precautions are not respected, can result in serious injury and even to fatal injuries to persons in close proximity to the machine,.*

To avoid serious or even fatal injury to the operator and persons in close proximity to the machine, it is important that the machine always is operated by trained, responsible personnel.

Description of the machine

The Pentruder 6 - 10 / Pentpak 15 represents a very modern and safe type of concrete wall saw. The Pentruder 6 - 10 / Pentpak 15 was developed and manufactured by **Tractive AB** in Sweden in a process where safety awareness, performance and reliability were the most important design parameters.

By taking advantage of experience and know-how built up over many years in this specialised field, this new design can offer the user great advantages, for example the markets best performance to weight ratio.

Pentruder 6 - 10 / Pentpak 15 offer outstanding quality. They are the culmination of exacting goals for quality and safety set at every stage from concept to finished product.

Saw head Pentruder 6 - 10 with accessories

The Pentruder 6 - 10 is the most efficient machine for concrete cutting available on the market today. The design offers many features to make your work safer, easier and more efficient.

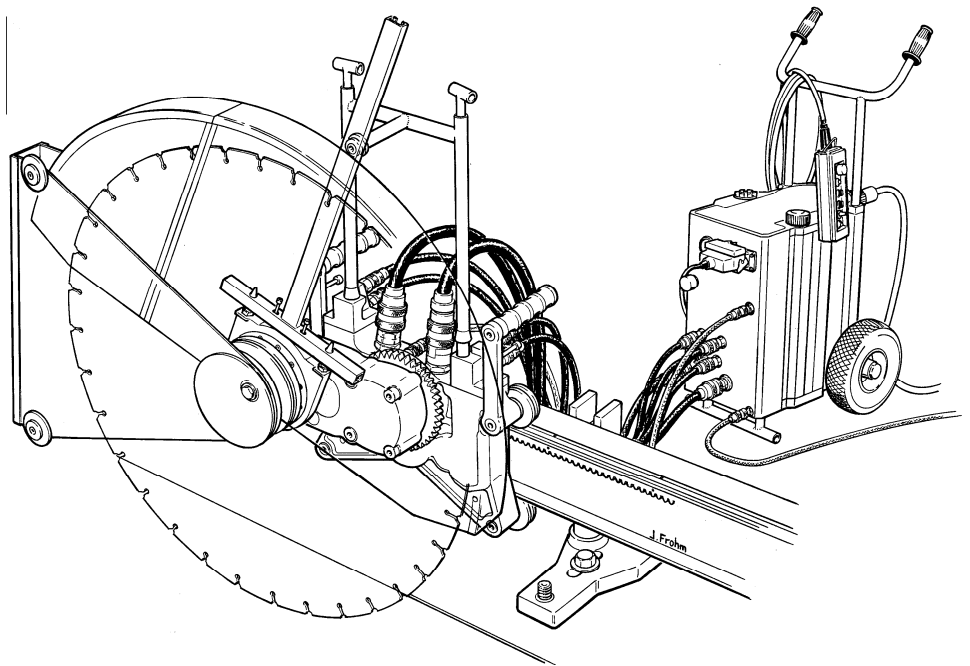

- Low weight, only 18.5 kg (41 lbs.) for a complete high performance saw head. For efficient cutting with blades from Ø 600 to Ø 1000 mm.
- Quick disconnect for the saw head. Eccentric rollers on the saw head allow it to be fitted and removed from the track with ease.
- 2-speed gearbox for optimum performance. The precision engineered gearbox offers unsurpassed performance and high efficiency in the transmission. The integrated gearbox simplifies the correct choice of peripheral cutting speed to match a chosen blade diameter.
- Conical self cleaning rollers offers optimum control of the saw head along the track. The rollers are easily adjustable and offer reliable operation over a long period of time.
- For optimum accessibility the saw arm can be rotated through 360 degrees in either direction.
- The saw head accepts a ø 800 mm saw blade free from the wall.
- Water feed to the blade is centrally over the blade flanges.

Quick disconnect coupling for mounting of the saw blade (Patent)

Tractive AB puts great emphasis on creating technical solutions for its products that are safe to use. This is the most important criteria when our machines are designed.

- Pentruder 6-10 is equipped with the same patented quick disconnect coupling for the saw blade as the bigger brother Pentruder 6-16. The intention with this coupling is primarily to enhance safety and handling. A unique patented coupling for the blade flange enhances safety and simplifies awkward set-up's considerably, especially when flush cutting must be performed. The saw blade can always be fitted after the machine is mounted, radially, and heavy and troublesome set-up's can be eliminated to a great extent.

Mounting a saw blade for flush cutting has always been relatively awkward and often one must mount the saw head and the saw blade together, and it can be difficult to mount also a normal saw blade for the upper or the lower cut, or even for vertical cuts if the available space is limited.

- With Pentruder's new quick disconnect all these problems are gone. Provided the operator is trained in the correct operation of the coupling it will provide considerable improvement on both safety and efficiency.

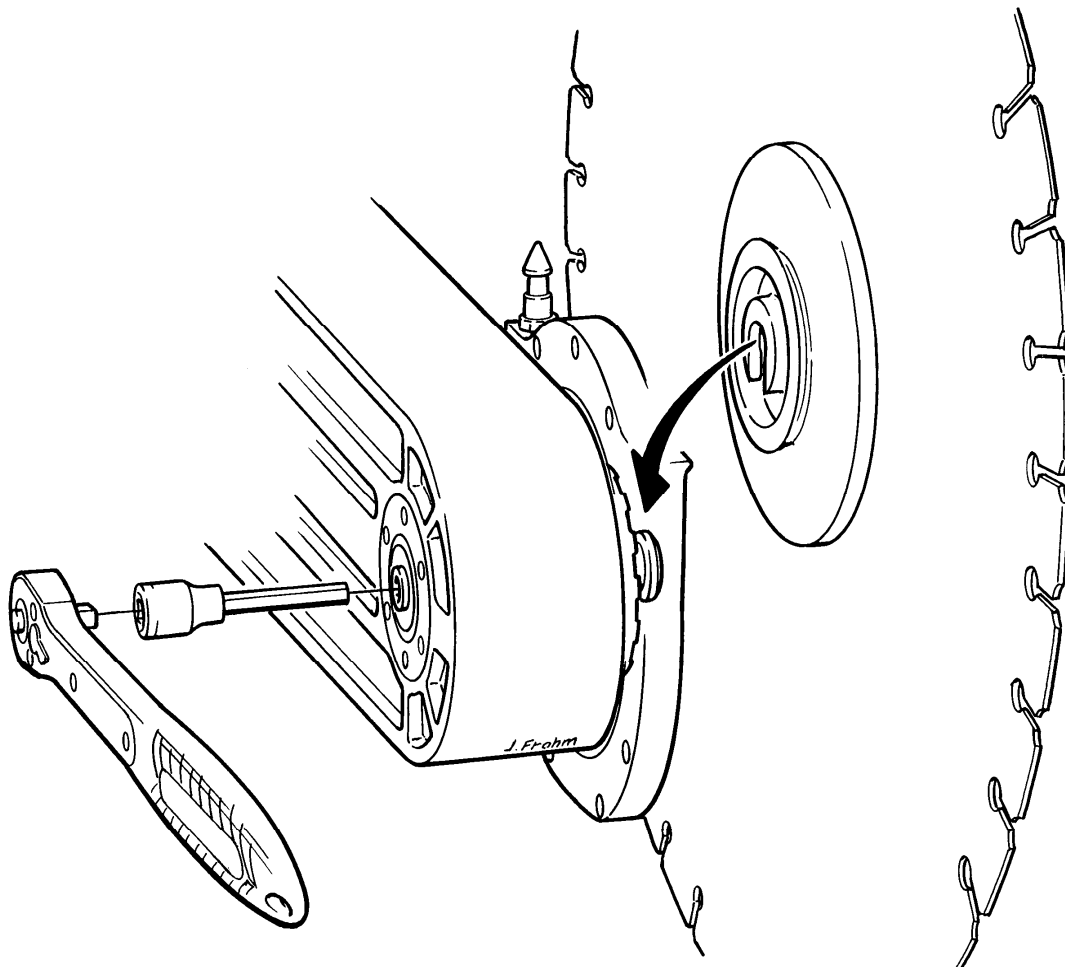

Tracks and brackets

The tracks and the brackets are designed to provide high levels of rigidity and stability for the lowest possible weight. The design is unique in the sense that it allows the guide rollers on the saw head to be aligned above each other, in the same plane as for the cut. This is to provide the highest levels of safety, stability and precision of cut.

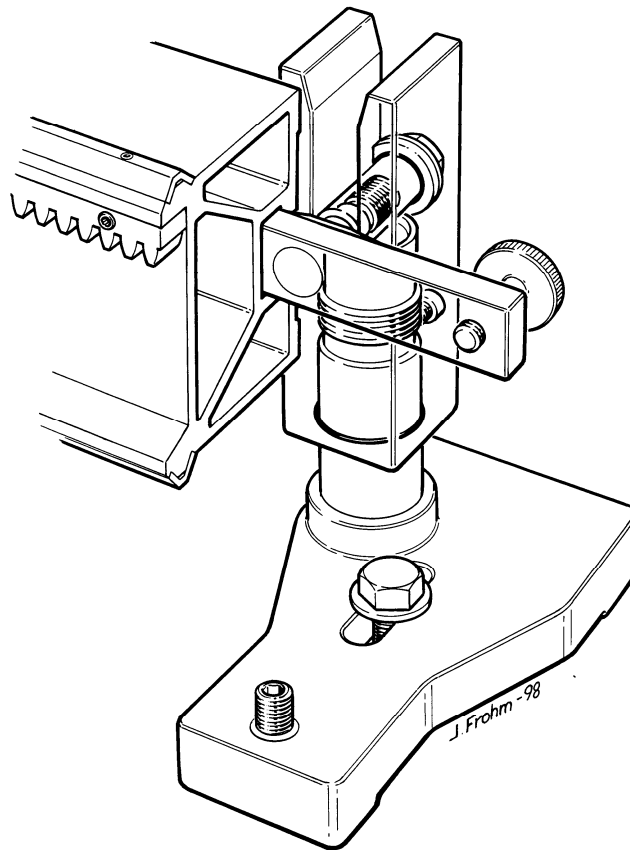

- The tracks are very lightweight at only 6.7 kg / m track. The stiffness and stability in the system is still, in spite of the low weight, sufficient for heavy loads and jobs where up to 1.6 m diameter (only for Pentrunder 6-16) blades are used.
- The tracks have steel guide rails on which the rollers run. They offer high wear resistance and precise guidance of the saw head. The grooves into which the guide rails are located have been machined with great precision.
- The tracks are quickly and easily mounted in an easily accessible yoke by means of a T-slot piece, which in turn is provided with a lubricated and protected screw and case hardened sleeve-type nut. The hardened sleeve-type nut safeguards that the screw preload is always adequate to clamp the track. This system improves safety and reduces the possibility of the nut working loose because of vibration or variations in load.
- The brackets are versatile and easy to use. A minimum of two brackets are needed to fit one track. When two tracks are joined, at least three brackets must be used, one of which must be mounted directly over the joint between the two tracks. The yoke is adjustable for height 12 mm to simplify adjustment over uneven surfaces.

Blade guard

The blade guards are made from sheets of hardened aluminium, screwed together with spacers to achieve strength and stiffness. The blade guards are available in four different sizes, Ø 800, Ø 1000, Ø 1200 and Ø 1600 mm. (Ø 1600 for Pentruder 6-16 only) The blade guards offers some interesting advantages compared to traditionally designed blade guards:

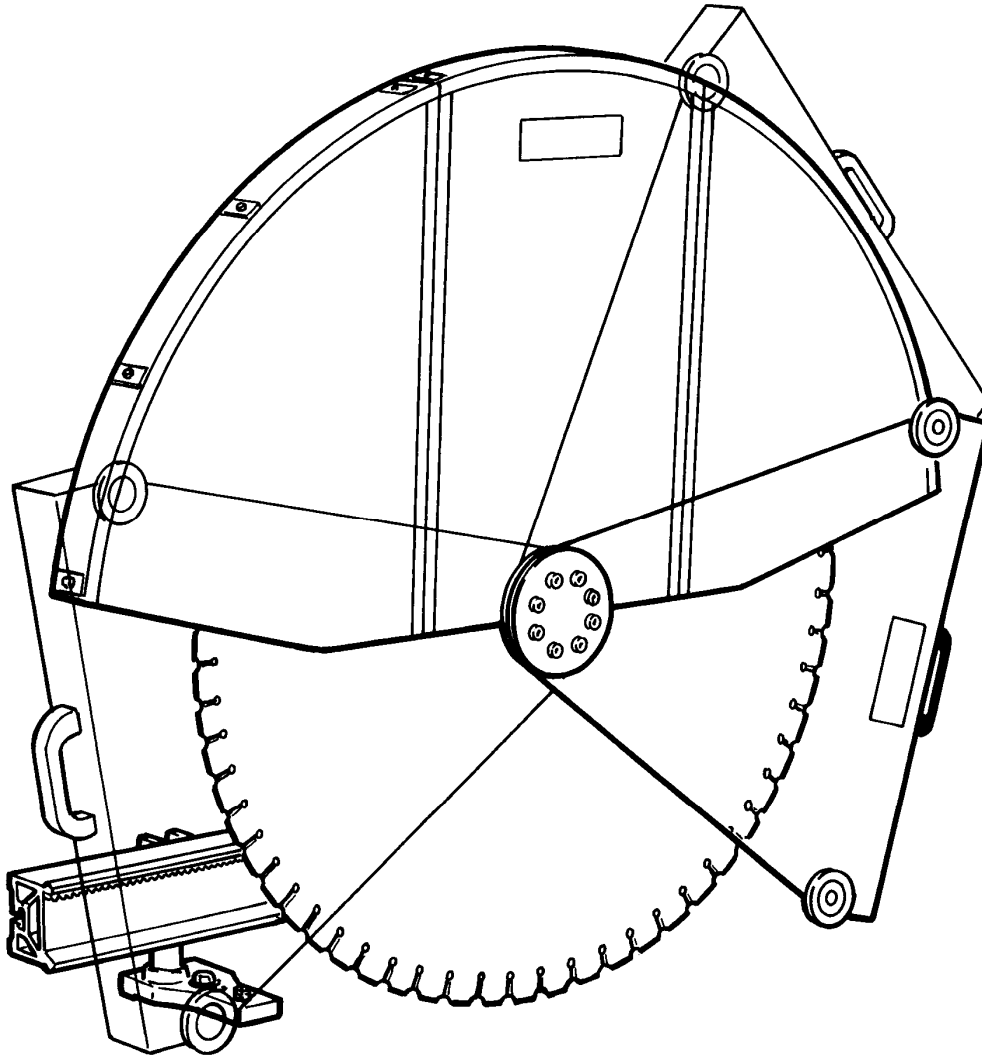

- New regulations put new and higher demands on safety, and thereby on the blade guards. Because of the lightweight design it is more likely that the operator will chose to use the blade guards on all jobs – this has not always been so! The guards on the Pentruder 6 – 10 are so convenient and lightweight they should always be used. It is a basic requirement for safe handling of the machine.
- Spray from the saw blade is reduced thanks to the extra swivelling splash guard.
- Automatic control of the blade guard through the movement of the saw arm, the operator need not adjust the guard manually while the machine is in operation.
- Detachable side pieces. The guards are divided in three pieces with a fixed centre piece and two detachable side pieces for cutting into adjacent surfaces.

Pentpak 15 Hydraulic Power Pack

The Pentpak 15 hydraulic power pack is designed to a new and unique concept, based on many years of experience and know-how in this field. The Pentpak 15 power pack is the most compact design on the market and offers outstanding performance combined with reliability, safety and ease of handling.

New regulations for the design of machines and the specifications for their inherent safety have been the ruling parameters in the design and development of this power pack.

Design, function and special features of the Pentpak 15.

- For optimum safety and manoeuvrability all functions are controlled through a hand held remote control unit. The operator can therefore always be in the safest and best possible position for complete control of the machine.
- The remote control system safeguards that a very high level of safety is achieved as all functions are reset automatically when the power supply is disconnected, or when any of the Emergency Stop-buttons are depressed. No functions remain after the power packs has been shut off. At every restart the power pack starts from the same initial mode with all functions reset.
- The electric motor is completely integrated in the design for superior power to weight ratio.
- The electric motor is water cooled by means of a specially developed system which provides excellent cooling of the motor around its entire periphery, no hot spots occur that can damage the motor.
- If the power pack is run using an inadequate supply of cooling water, the motor is still protected from overheating by means of a temperature sensing device. This sensor will shut off the power supply if the motor temperature exceeds a preset value.
- Normally water cooled electric motors are regarded to be prone to freeze and crack at sub zero temperatures. For the Pentpak 15 the risk is substantially reduced as the system empties itself as soon as the inlet and outlet water quick disconnect couplings and hoses are removed.
- Notwithstanding the diminutive dimensions and low weight of the Pentpak 15, 102 kg, the electric motor output is a remarkable 15 kW.
- The power pack is equipped with an electronic soft-start and can normally be run on 16 – 32 Amp fuses. 16 Amp delay fuses can be used for less demanding jobs, but the cutting capacity is then, of course, much reduced.
- All electrical and hydraulic equipment is protected under strong covers and can not easily be tampered with. The only device that can be operated is the Emergency Stop button and the feed regulation valve.

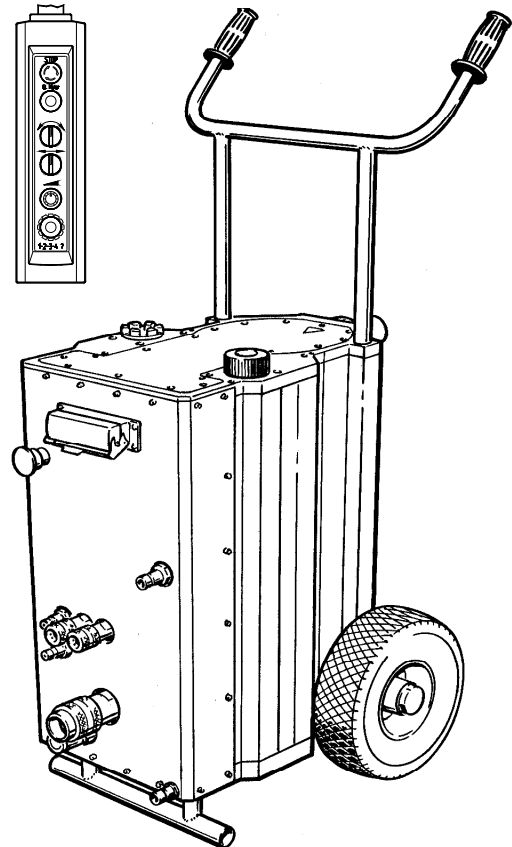

Intended use of the Pentruder 6 – 10 / Pentpak 15.

Pentruder 6 – 10 is intended to be used together with Pentpak 15, and may only be used for cutting of concrete and similar materials. It is our expressed recommendation that the machine may **not** be used for cutting in any other materials. Pentruder 6 – 10 can be used with other types of power packs, but in such a case Tractive AB disclaims any responsibility for the product.

Warning! *Observe that Tractive's responsibility as a manufacturer can only be accepted when the saw head, Pentruder 6 – 10, is used together with power packs, machines and accessory equipment of Tractive's manufacture and origin.*

Pentpak 15 is primarily intended to power Pentruder 6 – 10 hydraulic wall saw, but can also be used for powering other machines of our manufacture if a special flow divider is used. Please contact your dealer for information. Please observe that Tractive's responsibility as a manufacturer only can be accepted when the Pentpak 15 is used together with machines and accessory equipment of Tractive's manufacture and origin.

Important! *Always consult Tractive AB or our representative before any other type of machine or equipment than the Pentruder 6 – 10 is connected to the power pack. Observe that Tractive's responsibility as a manufacturer can only be accepted when the saw head Pentruder 6 – 10 is used together with power packs, machines and accessory equipment of Tractive's manufacture and origin.*

All Tractive power packs including Pentpak 15 supply pressure in the **FEMALE** coupling fitted on the power pack, and return oil in the **MALE** coupling on the power pack.

Safety precautions

It is of paramount importance that the operator has full knowledge and understanding of the instructions below:

This wall saw may not be used unless the operator is fully familiar with the contents of this manual and has been trained in its operation by an authorised distributor of Tractive AB's products. The operative is fully responsible for the manner in which the machine is operated. It is the responsibility of the purchaser that the operator has received the information needed to operate and handle the machine in a safe a correct way.

Warning! *Faulty handling of the machine can expose the operator and / or persons in close proximity to the machine to danger.*

Tractive AB disclaims all responsibility for damages to persons and / or property resulting from use of the machine, whether they are caused by faulty handling or from damages that have occurred as a consequence of negligent or faulty maintenance, or as a consequence of failure to check and control the machine with regard to damages and / or faults.

Warning! A Pentruder wall saw used in the correct way is a safe and efficient tool. If the machine is used improperly this can expose the operator and other persons staying in the same area to extreme danger or even risk of fatal injuries.

Warning! Basic safety precautions are that all persons present in the same area or in the same place as the machine shall wear protective equipment including helmet, safety shoes, gloves, eye and ear protection, and that all other safety precautions applicable on site are to be respected.

Warning! A saw blade rotates at up to 60 m/s peripheral speed, i.e. over 200 km/hour (120 mph). The energy stored in such a blade is considerable, and it is always important that the machine always is mounted according to the instructions given in this manual, and that the blade guard is **always** fitted.

Warning! Always check that the equipment is in faultless condition and that all functions are in order before work is commenced.

Warning! Never connect the hydraulic hoses to either saw or power pack while the power pack is running. The power pack must be disconnected from the power supply by removing the 32 Amp plug and cable from the power pack before any hydraulic connections are made.

Warning! The power pack must always be switched off and the 32 Amp plug and cable disconnected from the power pack before any kind of service is commenced, for example filling of oil, oil change and filter replacement.

Warning! Mounting and dismounting of the saw head may only take place when the saw head is disconnected from the power pack by removing the two large hydraulic hoses from the saw head.

Warning! Mounting and dismounting of the **blade guard and saw blade** may only take place when the saw head is disconnected from the power pack by removing the two large hydraulic hoses from the saw head.

Warning! Track brackets may only be mounted according to the instructions given in this manual.

Warning! To maintain the level of safety inherent in the design of this machine, only Tractive original spare parts may be fitted. Tractive AB disclaims all responsibility for damages occurring as a result of use of non original parts.

Important! The power pack must only be operated when in an upright position.

Important! The power pack is water cooled and must be drained from water when the ambient temperature is in the proximity of or below 0 degrees Celsius.

Important! The electric motor of the power pack is water cooled and the water pressure must therefore be limited to max 5 bar. The incoming water supply may only be connected to the lower connection on the power pack. The quick disconnect couplings may not be replaced with couplings that are not fully open when disconnected.

Important! Connect the power pack only to Pentruder 6 – 10 or such equipment which has been manufactured or approved by Tractive AB.

Getting started

Preparations before commencing work

Certain preparations must be done before starting work. If questions arise that can not be answered by reading the three first sections of this manual, there is a word list in the 4:th section of this manual which may give additional information on a particular issue.

- Cleaning:** The machine should be carefully cleaned after each job is completed. All functions must be checked and be found normal before use of the machine.
- Tools:** Use only those tools that are intended to be used to operate the machine: Ratchet ½", socket 19 mm, Allen-socket 8 mm, T-shape 8 mm Allen key .
- Quick disconnects:** Check all quick disconnect couplings for correct function and cleanliness.
- Guide rollers:** Check that the guide rollers on the saw head can move freely without too much friction. A certain amount of friction is always present as the bearings are double sealed with both rubber and steel scraper seals.
- Remote Control unit:** Check the remote control unit for correct function and that the multi-pin-plug is free from dirt and undamaged.
- Water feed:** Check that the machine can be supplied with clean cold water, minimum 8 L / minute.
- Hoses:** Check that all hoses are the correct type, R2 for the main 5/8" hoses, and that they are in faultless condition.
- Oil level in the power pack:** Check the oil level in the power pack. The correct level is 2/3rd up on the level indicator with the motor switched off.
- Power supply:** Check if sufficient power is available on the site. The machine should be connected to a 5-pin 400 V 3-phase supply with minimum 16 Amp fuses.
 Current idling 9 Amp
 Current at 8 kW 16 Amp
 Current at 15 kW 30 Amp
- Safety precautions on the site:** Check with the foreman responsible that all necessary precautions have been performed before commencing work. Await the approval of the safety precautions and mounting position of the machine from a responsible person before work is commenced.

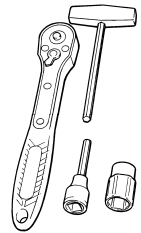

Warning! If there is a possibility that cut concrete blocks may fall causing injury or damage to persons or property then they must be secured before starting work. The risk area must be roped off and a responsible person left in charge, in a safe place, to prevent entry of unauthorised persons.

Preparation and mounting of track feet and tracks

Positioning of feet: The track feet and the tracks should be mounted in such a way that they can not become detached when the machine is working, or at sudden changes in load on the anchor bolts.

The track feet are designed to fit the track to the surface the machine will work on. The feet must be fixed by means of M12 x 50 screws of 10.9 quality, or better, using a thick washer and anchors of type HKD M12 or equivalent. Se picture below.

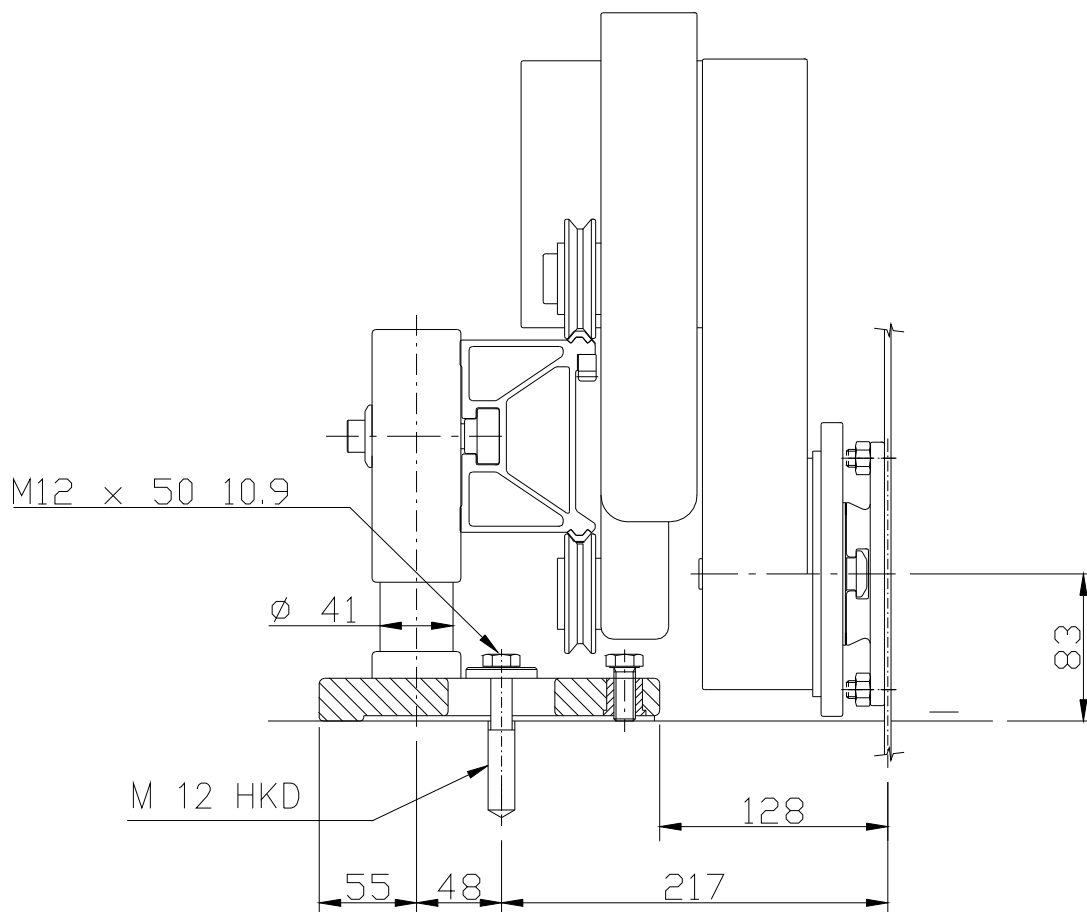

Warning! If HKD anchors or an other high quality expansion anchor can not be fixed securely, the track feet must be securely fixed with through bolts and large washers to achieve the required level of safety.

Positioning of feet: The track feet should preferably be mounted in the position shown in the picture above. The distance from the edge of the feet to centre of cut is then 128 mm. The distance from anchor bolt to centre of cut is 217 + 25 mm.

Alternative position of track feet:

In certain circumstances it is impossible to mount the track feet as shown in the picture below. If the track feet must be mounted differently, this may affect the stability of the track. If this is the case, more track feet should be fitted to spread the load and increase stability.

Mounting the track:

The track is mounted using clamp screws which fit into the yoke of the track foot. At least two feet must be used to mount one track.

The clamp screws are fitted in T-slot clamps running in T-slots at the rear of the tracks. These T-slot clamps can be locked in any position by means of a knurled knob.

A clamp screw is fitted in to the yoke and should be tightened to 50 Nm (fairly hard) with a 19 mm key.

Warning! Be careful to position the clamp screw in the countersink of the yoke on the track foot. This countersink is to prevent the track coming of the feet in case the clamp bolt is not tightened properly.

Joining two or more tracks together:

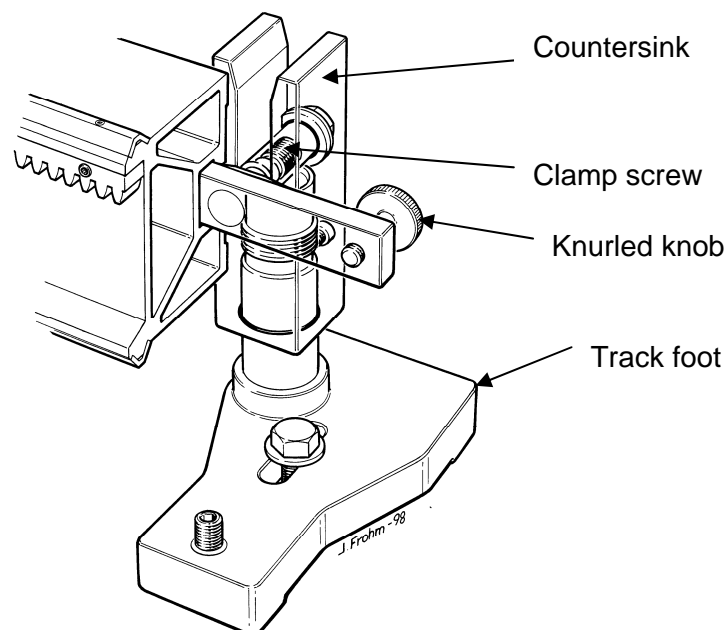

If tracks are to be joined when making long cuts the yoke of the mounting foot should

Mounting the saw head on the track (AND shifting gears)

Mounting and demounting the saw head:

The saw head runs on the track on four conical rollers. The upper rollers are fitted on eccentric shafts, opened and locked by folding the lifting handles. Fold the saw onto the track, the upper “eccentric” rollers engaged first. Move the saw head slightly along the track to engage the travel gear with the rack, then fold the saw completely on to the track, pull the locking pins and turn the handles outward until the locking pins engage with handles in the open position.

Warning! Before the saw is operated, always check that the eccentrics are locked in position to prevent the saw from falling off the track. Do not turn the handles unless the locking pins are lifted.

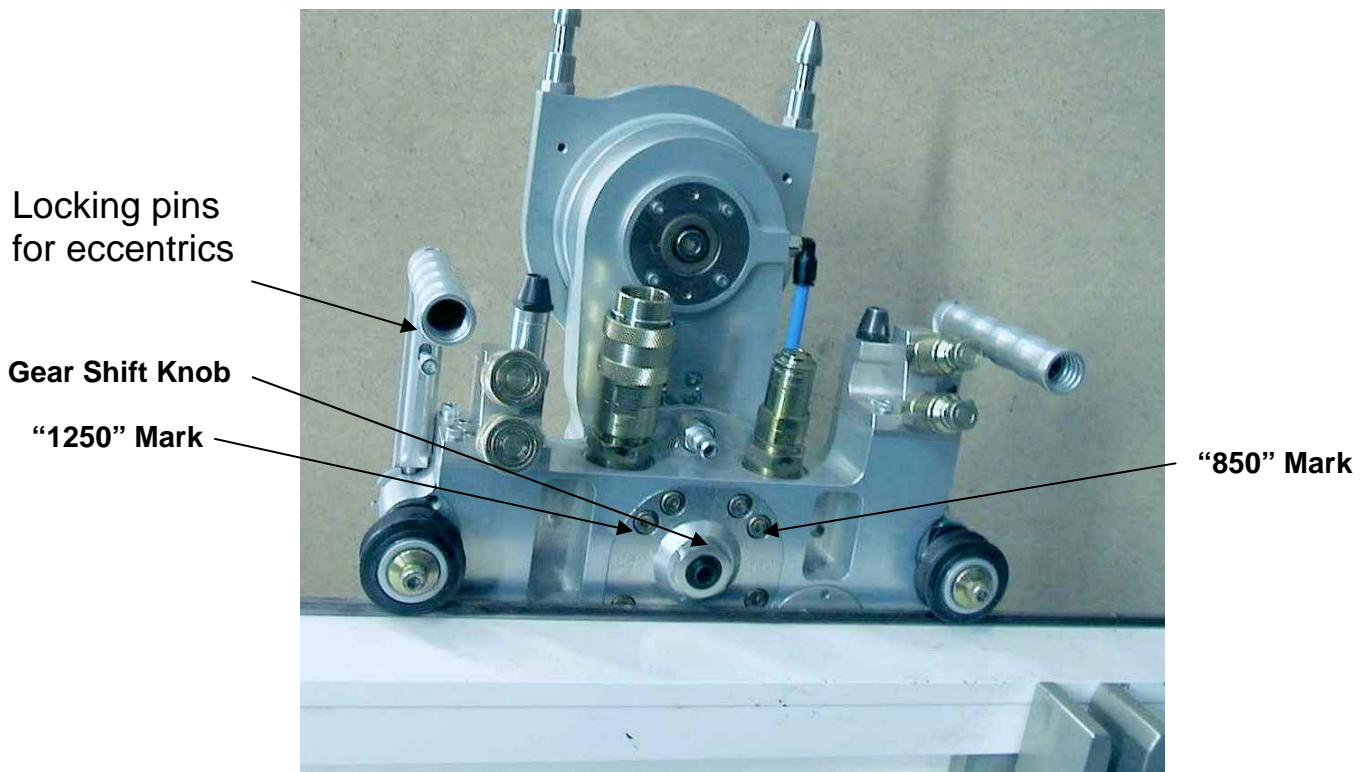

How to shift gears in the 2-speed gearbox

- Gears may only be shifted when the two big hydraulic hoses are disconnected from the saw head, as shown in the picture above.
- The gear selection knob is placed below and between the big hydraulic couplings. To the left of the button, there is a marking “1250” for the high speed and to the right of the button there is a marking “850” for the low speed.
- If the knob protrudes approximately 12 mm from the seal lip, or 14 mm from the hexagon, low speed is selected. If the knob is nearly flush with the seal lip, high gear is selected
- To shift to high gear, push in the knob using a 8 mm T-key and turn the blade slightly while turning the knob CCW 90 degrees. To shift from high gear, turn the knob CW and release it. Turn the blade until the knob pops out. It should protrude approximately 12 mm from the seal lip, or 14 mm from the hexagon. **Important: If the knob is not in its fully out position, and the machine is started, gearbox damage will occur.**

Quick disconnect coupling for the saw blade

Function principle:

The saw blade is fitted on a blade flange by means of an outer collar and clamped by means of a special centre screw, or, for flush cutting, on a special flush cutting flange by means of 6 countersunk screws and nuts.

The blade flange, regardless of type, is provided with a radial T-slot to the centre of the flange. The flange, with blade fitted, is mounted on the machine spindle and its pull stud which fits in to the T-slot in the flange. When the coupling is tightened with the locking screw at the rear of the spindle, the flange is clamped towards the machine spindle by the pull stud which then moves inwards.

The flange and the spindle are provided with drive dogs to transmit the torque to the blade. The dogs must always be aligned, in mesh, for the coupling to work properly.

At the same time as the pull stud moves inwards, a conical centering ring moves outwards to centre the flange on the spindle. This ring at the same time interlocks the coupling by blocking the T-slot.

This principle is very safe, as it does not require more than one single operation to be carried out to clamp and interlock the coupling. Even if the coupling is not completely tightened the saw blade can't fall off the spindle as the conical ring keep the blade on the spindle. It is however very important that the dogs are completely in mesh before the coupling is tightened.

See Warning on next page!

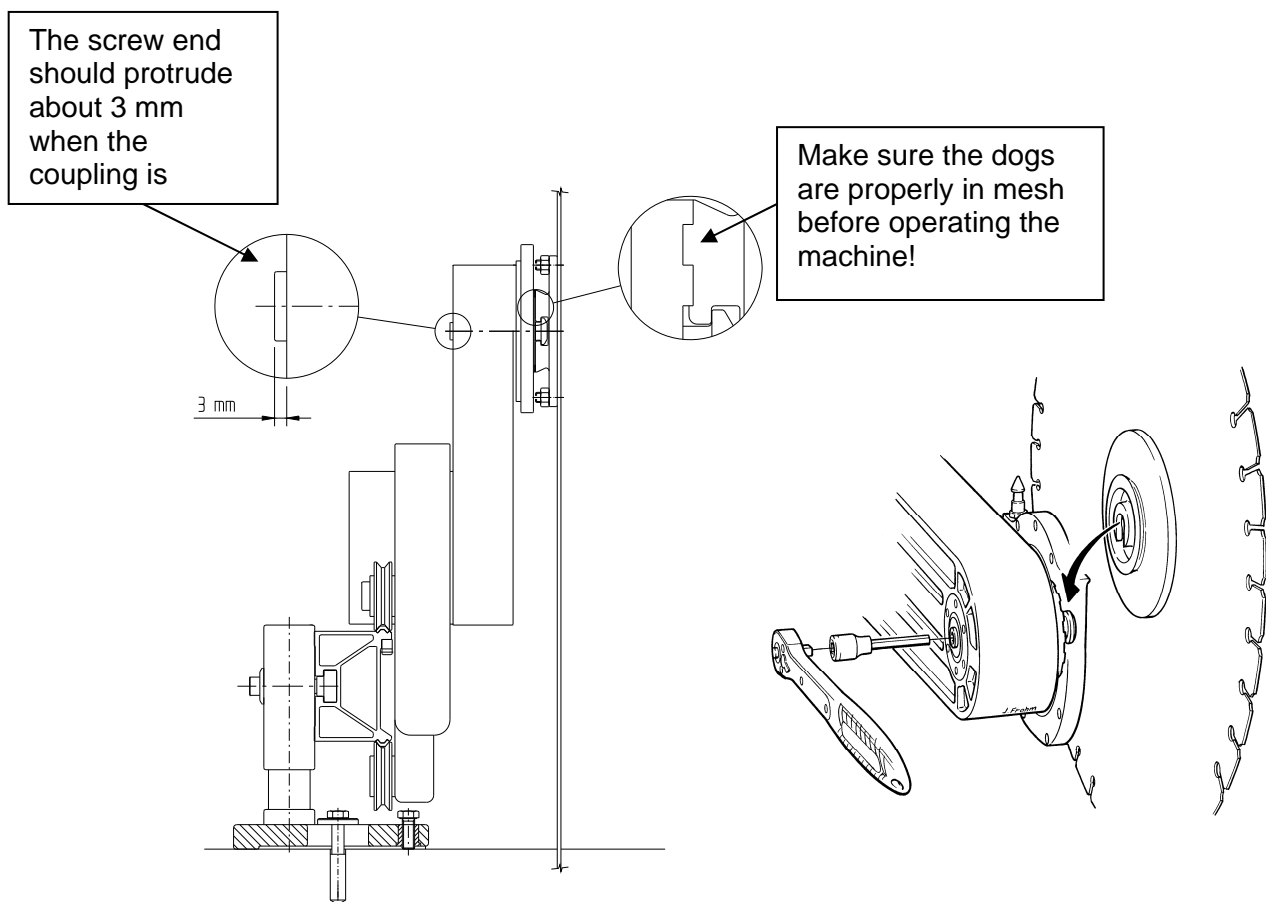

Warning! Never fit the blade and flange to the saw spindle before first disconnecting the two 5/8" hoses (the two biggest) from the saw. This important rule must always be strictly followed to ensure that the blade motor cannot be inadvertently started. Failure to follow this instruction may result in serious personal injury or death.

The power pack can be placed out of sight of the operator, maybe 30 m's away, or on a different level, and the only way to protect the operator from accidental starting of the blade motor is for the operator to always disconnect the two 5/8" hoses. With these hoses disconnected no hydraulic power can go to the saw head.

Warning! The drive dogs on the machine spindle and blade flange must be completely in mesh before the clamping screw is tightened to prevent damage to the coupling. Failure to follow this instruction may result in serious personal injury or death.

How to fit a blade on a normal blade flange:

Centre bore: The saw blade should have a hole with diameter 60 mm $-0 +0.1$ mm, and be free from cracks, dents, burrs and dirt.

Transmission of torque: The friction surfaces of both the flange and the blade must be free from grease and dirt to be able to securely transmit the torque of the saw blade motor without slippage. Slippage will cause irreparable damage to the flanges.

Clamping: The blade is fitted on the inner flange and is clamped by the outer collar with a special centre bolt. The centre screw should be tightened to about 40 Nm.

Mounting on the machine spindle: The blade and flange are now ready to be fitted on to the machine spindle with the quick coupling..

Warning! The saw blade must always be fitted correctly to avoid danger. The instructions given above must always be followed to avoid faulty mounting of the blade.

How to fit a blade on a flush cutting flange:

Centre bore: The saw blade should have a hole with diameter 60 mm $-0 +0.1$ mm, and be free from cracks, dents, burrs and dirt.

Clamping: The blade is fixed with 6 countersunk screws. The bolt circle and size varies depending on market and supplier of the blade.

Bolt circle: A 130 mm bolt circle is commonly used with 6x M8 screws.

When a blade is fitted to a flush cutting flange, it is very important for safety to respect the following instructions:

Screw quality and torquing of screws: The blade must be clamped with countersunk screws from Unbrako and be of quality 10.9. The nuts must be of type "Nyloc" and the fasteners must be torqued with a torque wrench to 35 Nm for M8 screws. The threads must be lubricated with grease or oil.

Warning! *The saw blade must always be fitted correctly to avoid danger. The instructions given above must always be followed to avoid faulty mounting of the blade, which in turn can cause serious personal injury or death.*

Warning! *It is important to be aware of the fact that when a flush cutting blade is used, the blade is clamped merely by the six countersunk screws, nothing else.*

Important! *The blade must have a bolt circle where the holes are spaced on an even and exact spacing to prevent unequal load distribution on the screws, blade and flange*

Mounting on the machine spindle: The blade and flange are now ready to be fitted on to the machine spindle with the quick coupling.

Peripheral cutting speed and spindle speed

There are two principal reasons for the peripheral cutting speed to be adjusted:

- The blades are of different diameter for different requirements on cutting depth. The peripheral cutting speed should be approximately the same regardless of diameter. A larger diameter blade will rotate at a lower speed than a small one and vice versa.
- Concrete can be very different depending on the aggregates used, how much steel reinforcement is used etc. Therefore it can be necessary to adapt the peripheral cutting speed to the quality of the concrete, all depending on the type, quality and condition of the saw blade. A rule of thumb is that harder concrete and/or high content of steel is more easily cut with lower speeds than normal, and vice versa.

The Pentruder 6 - 10 is equipped with a 2-speed gearbox to simplify adaptation of the peripheral cutting speed to conditions and size of blade. No adjustment of oil flow from the power pack is necessary.

Important! If low speed is selected, always check that the shift knob is released properly, it should protrude approximately 12 mm from the seal lip, or 14 mm from the hexagon, when low speed is selected. If the machine is started and the knob is not in its correct position, gearbox damage will occur.

		Peripheral speed in Meter/sek with Saw blades ø						
Gear	RPM	500	600	700	800	900	1000	1200
LOW	850	22	27	31	36	40	45	53
HIGH	1250	33	39	46	52	59	Not allowed	Not allowed
Depth of cut mm		167	217	267	317	367	417	517

The peripheral speeds above in bold style are recommended max. speeds for flint and hard concrete.

Warning! The gear selection knob may not be operated before first disconnecting the two 5/8" hoses (the two biggest) from the saw. This important rule must always be strictly followed to ensure that the blade motor cannot be inadvertently started. Failure to follow this instruction may result in serious personal injury or death.

The power pack can be placed out of sight of the operator, maybe 30 m's away, or on a different level, and the only way to protect the operator from accidental starting of the blade motor is for the operator to always disconnect the two 5/8" hoses. With these hoses disconnected no hydraulic power can go to the saw head.

Mounting the blade guard

New safety regulations means that greater emphasis has to be put on safety, and therefore on the blade guards, and these can now, thanks to a new and better design, remain on the machine at all times when the blade is running. A prerequisite to achieve any level of protection is that the guard is fitted to the machine at all times. The guards come in 4 different sizes, Ø 800, Ø 1000, Ø 1200 and Ø 1600. (Ø 1600 only for Pentruder 6-16)

The blade guard is automatically controlled by the movement of the saw arm, and the operator does not have to adjust the guard while the machine is running. The guards consists of three main pieces, a middle main piece and two detachable side pieces. A pivoting shield is provided to contain overspray from the blade. It should be adjusted before starting to cut.

The guard is mounted by entering the grooved bushing into the C-profile on the guard and then pushing the T-bar with the two holes in it on to the two tapered bolts on the saw arm. Then the safety lock is slid down and secured with a 8 mm Allen key. To remove the guard, first remove the safety lock and press the two locking screws on the guard together and take off the guard.

Warning! The blade guard has many functions. The most important one is to protect the operator and other persons from accidental injury. In a situation when, for example, the operator or someone else accidentally falls against the machine, the guard is there to as well as possible protect against contact with the running blade. In other potentially dangerous situations, for example if a cracked or faulty blade is used, or if the blade is not properly fitted, or the quick release coupling is improperly used, the guard is there to reduce the damage done by a blade.

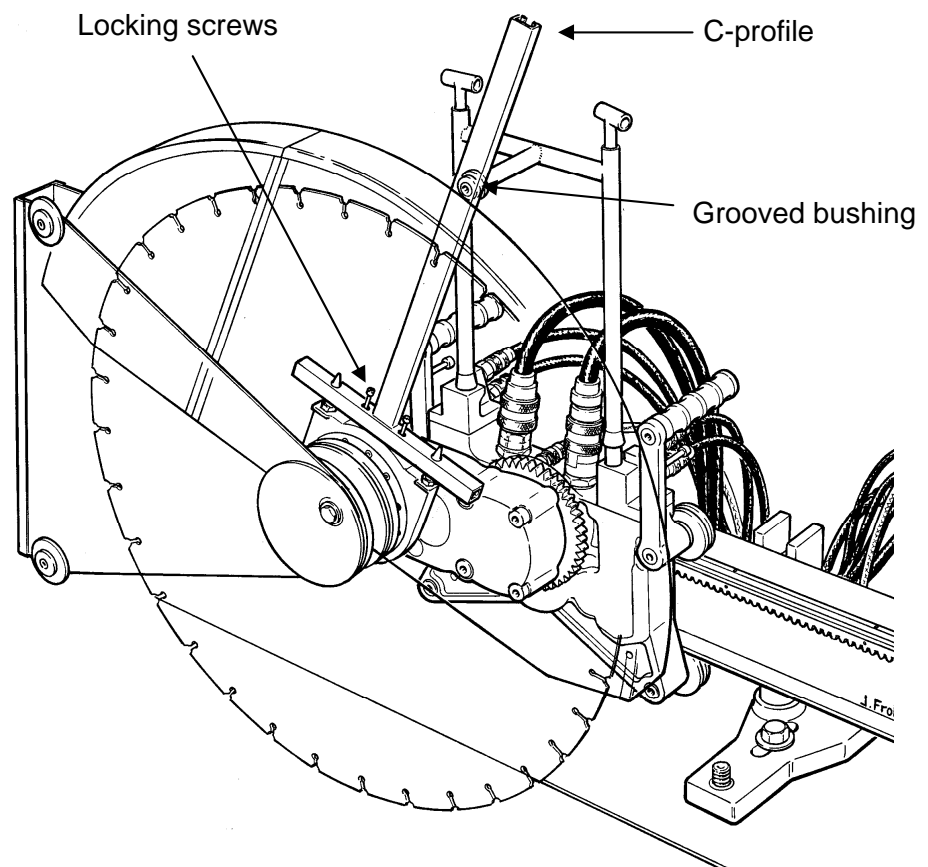

Normally the function of the blade guard is to protect the operator and the surrounding area from the water and loose material which is cut away by the blade and thrown out of the cut. To give any protection at all, the blade guard must be mounted at all times when the blade is rotating under hydraulic power. The instructions above must always be followed. Failure to follow this instruction may result in serious personal injury or death.

Warning! The blade guard may not be fitted or removed before the two 5/8" hoses are disconnected from the saw. This rule must always be followed to eliminate that the blade motor is started by accident when the operator is working on the saw head. Failure to follow this instruction may result in serious personal injury or death.

Preparing the power pack

Positioning: The power pack should be positioned away from where the sawing takes place and should be kept dry at all times. It should preferably be placed on a flat surface. If this is not possible the power pack should be positioned so that the black filler cap is on the highest level possible to avoid oil leakage when the hydraulic oil warms up and expands during running of the machine.

Avoid leaving the power pack outside in the rain. The unit is fully sealed and correctly ventilated but to prevent possible damage to electronic components we recommend that it is kept dry to prevent condensation forming.

Hydraulic connections: Hydraulic power to the blade motor is supplied by two identical 5/8" 6 m long hoses. The feed and travel motors are supplied by 2 + 2 1/4" hoses with the same length, packaged together with a 10 mm water hose. All hydraulic couplings are arranged in such a way that they can only be connected in the correct way.

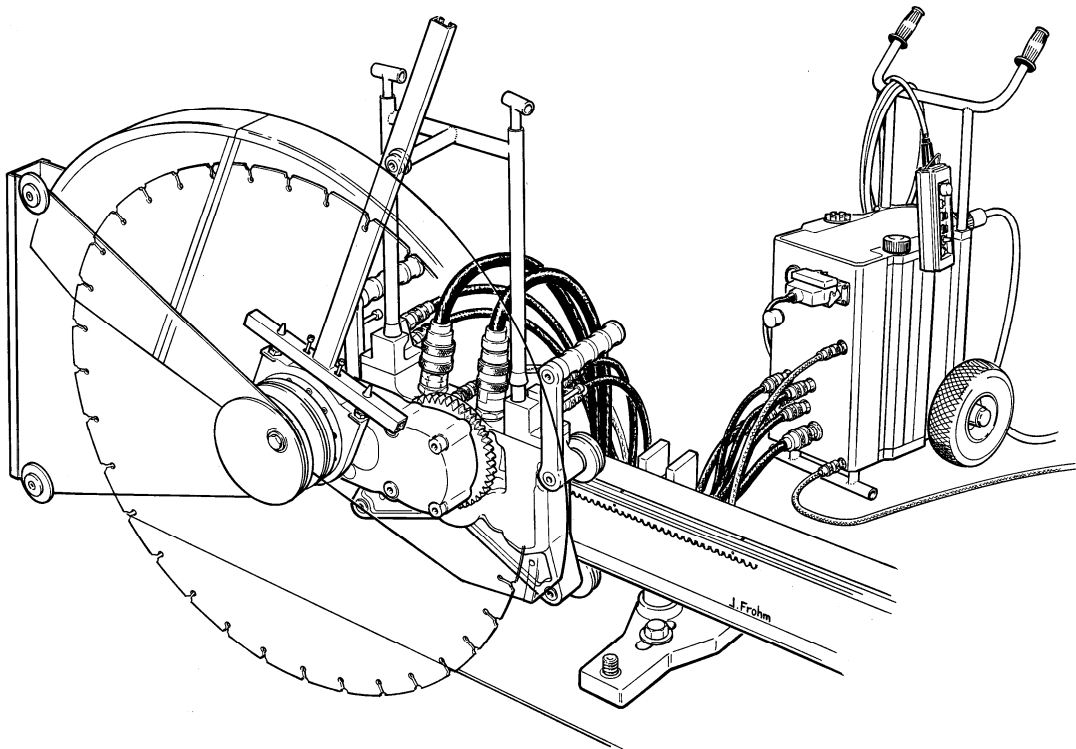

Warning! The power pack must not be connected to the electrical supply until all hoses are first connected to the saw and power pack.

Connection to water supply:

The power pack is water cooled and needs a minimum of 8 litres of cool water per minute at full power output. The water pressure should be at least 1 bar. The water supply may only be connected to the lower connection on the power pack, never to the upper one. The upper connection is connected to the water hose running up to the saw.

Important! The water couplings may never be substituted for coupling with a closing valve when disconnected as water then will remain in the oil cooler and in the electric motor cooling jacket. Leaving water in the power pack will destroy these components in sub zero temperatures.

Connection to remote control:

The power pack must be disconnected from the mains when the remote control is connected. The multi pin connector must be in the correct position for the clamping latch to close.

Power supply:

The power pack should be connected to a 5-pin 400 V 3-phase supply with minimum 16 Amp fuses.

Current idling 9 Amp
 Current at 8 kW 16 Amp
 Current at 15 kW 30 Amp

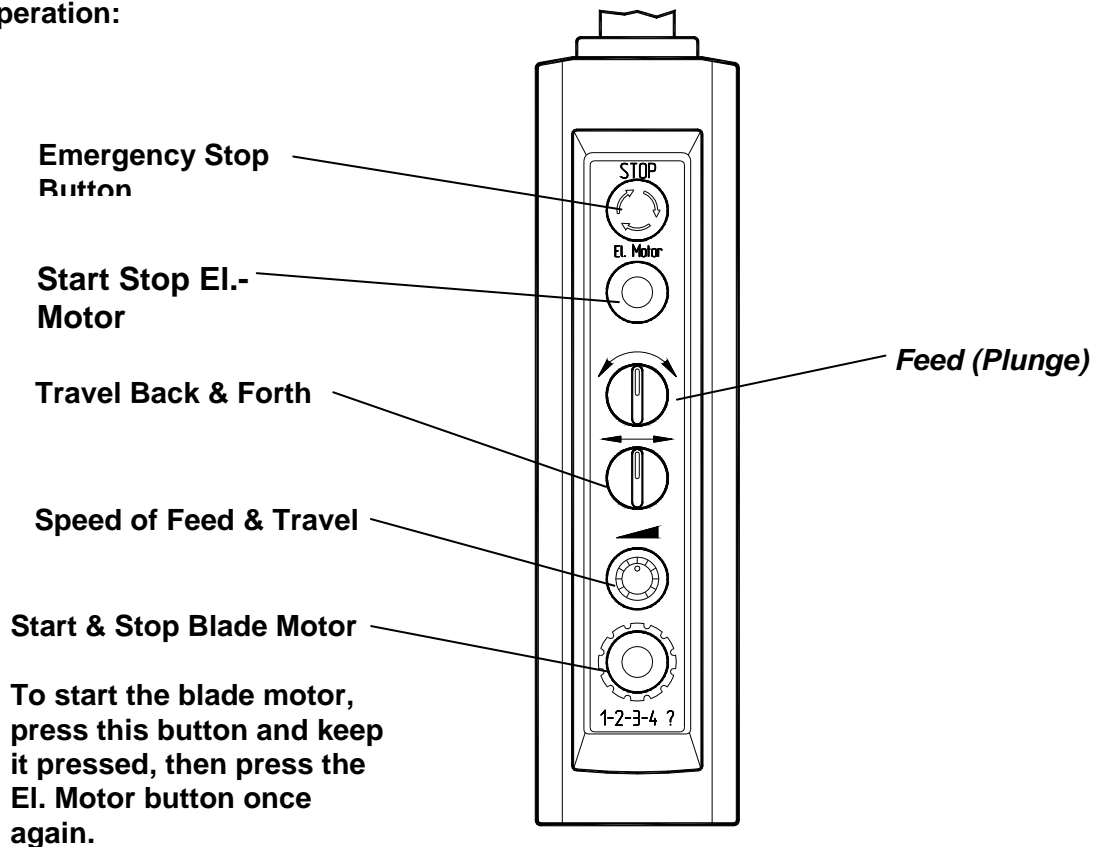
Operation:

To start the blade motor, press this button and keep it pressed, then press the El. Motor button once again.

Connecting to mains:

The power pack should be connected to a 400 V 50 Hz power supply with at least 16 Amp fuses. The power pack is equipped with a 32 Amp socket. An adaptor must be fitted when other cables or supplies are to be used.

Warning! The power pack may not be electrically connected when the hydraulic hoses are connected.

Warning! Never connect the hydraulic hoses to either power pack or saw head when the power pack is running. The power pack must be switched off and disconnected from the mains by removing the 32 Amp plug before any of the hydraulic hoses are connected.

Warning! Be sure to lock the 5/8" hydraulic couplings by turning the sleeves on the female couplings after they are connected.

Word list

Blade guard The blade guards are made from hardened aluminium sheet metal and their function is to protect the operator from water and debris which is thrown out of the cut. The blade guard has many functions. The most important one is to protect the operator and other persons from accidental injury. In a situation when, for example, the operator or someone else accidentally falls against the machine, the guard is there to as well as possible protect against contact with the running blade. In other potentially dangerous situations, for example if a cracked or faulty blade is used, or if the blade is not properly fitted, or the quick release coupling is improperly used, the guard is there to reduce the damage done by a blade.

Normally the function of the blade guard is to protect the operator and the surrounding area from the water and loose material which is cut away by the blade and thrown out of the cut.

To give any protection at all, the blade guard must be mounted at all times when the blade is rotating under hydraulic power. The instructions above must always be followed.

Note! See warning on page 18.

Blade motor, shutting off The blade motor is started and stopped electrically via the remote control unit. It is important to stop the blade completely before turning off the electric motor in the power pack, especially when using large diameter blades. Otherwise oil is pumped in circulation by the coasting blade and oil can be forced out through the filler cap.

Blade, replacing using the quick disconnect coupling The saw blade is fitted on a blade flange by means of an outer collar and clamped by means of a special centre screw, or, for flush cutting, on a special flush cutting flange by means of 6 countersunk screws and nuts.

The blade flange, regardless of type, is provided with a radial T-slot to the centre of the flange. The flange, with blade fitted, is mounted on the machine spindle and its pull stud which fits in to the T-slot in the flange. When the coupling is tightened with the locking screw at the rear of the spindle, the

flange is clamped towards the machine spindle by the pull stud which then moves inwards.

The flange and the spindle are provided with drive dogs to transmit the torque to the blade. The dogs must always be aligned, in mesh, for the coupling to work properly.

At the same time as the pull stud moves inwards, a conical centering ring moves outwards to centre the flange on the spindle. This ring at the same time interlocks the coupling by blocking the T-slot.

Note! See **Warning** on page 15!

Blade, replacing without using the quick disconnect coupling The saw blade is mounted on the inner blade flange and clamped in place by the outer collar and a special clamp screw. The screw should be tightened to about 40 Nm. **Note!** See Warning on page 15.

Bolts for flush cutting blades. Flush cutting blades are held just by 6 countersunk screws. This means that the blades that are fitted for flush cutting must be properly fixed to the machine. The screws that are used, M10 for 108 mm and 110 mm bolt circles, M8 for 130 mm B.C., must be properly tightened, using a torque wrench. The correct torque for M10 10.9 quality screws is 60Nm. The correct torque for M8 10.9 quality screws is 32Nm. Grease the threads and always put a socket on the nut, not on the screw, and tighten to the specified torque.

Cut For all cuts it is of greatest importance that the cut is a straight and clean as possible to avoid unnecessary friction and wear. We recommend that a shallow 4 – 6 pre cut always is taken before deeper cuts are performed. See also **Pre cutting**.

Cutting with big diameter blades When cutting with big diameter blades one must take into consideration the fact that a big and heavy body is brought to rotate at considerable speed. This body, the blade, will store a great amount of energy which will have to be dissipated in case something unforeseen happens.

To dissipate this energy safely in case something unforeseen happens, for example if the blade is jammed in the cut, it is of paramount importance that the track feet and tracks are secured safely to the surface the machine is mounted to.

The most common risk when using big diameter is the case mentioned above, when a blade is jammed in a cut. What happens then is that the blade suddenly starts to rotate around a different centre of rotation than what was originally intended. The blade starts to rotate around a new centre, which is the point where the blade is jammed, and this can cause great loads on the saw head and its supporting structure.

The most likely scenario to develop is that the blade puts considerable force on the saw arm and tries to move the real blade centre. On the Pentrunder this situation is catered for as there is a shear pin built in which shears and allows the arm to rotate a small amount and thereby takes the position where the energy can be dissipated into the supporting structure, i.e. the track and the track feet.

This is a situation which may occur once in five years, or maybe three times a year, all depending on conditions.

When a shear pin is broken it must be replaced, which is a fairly straight forward exercise.

For deep cuts blades up to 1.600 mm diameter can be used. When cutting to reach a big depth, max 715 mm, blades with successively bigger diameter are used until the desired depth of cut is reached. To do this efficiently it is our recommendation that a special 600 mm pre cutting blade is used as the first blade. A pre cutting blade is wider and stiffer than a normal blade and will provide the stability which is required to make a perfectly straight and clean cut, reducing friction against the sides of the cut for the subsequent bigger blades. After the pre cutting blade has reached its maximum depth, a 1000mm blade can be mounted, thereafter, if required, a 1200 and lastly a 1600 mm blade.

For very thick constructions and/or when wire sawing is not applicable, cuts can be taken

from both sides. See also **Deep cuts**, and **Pre cut**.

Cutting depth It is more economical to cut relatively shallow cuts for each pass along the cut than trying to take everything in one or 2 passes. To achieve optimum cost performance ratio we recommend that each cut is between 60 – 120 for each pass, in normal concrete. For tough flint concrete we recommend 20 – 50 mm for each pass.

Deep cuts For deep cuts blades up to 1.600 mm diameter can be used. When cutting to maximum depth of 715 mm, blades with successively bigger diameter are used until the desired depth of cut is reached. To do this efficiently it is our recommendation that a special 600 mm pre cutting blade is used as the first blade. A pre cutting blade is wider and stiffer than a normal blade and will provide the stability which is required to make a perfectly straight and clean cut, reducing friction against the sides of the cut for the subsequent bigger blades. After the pre cutting blade has reached its maximum depth, a 1000mm blade can be mounted, thereafter, if required, a 1200 and lastly a 1600 mm blade.

For very thick constructions and/or when wire sawing is not applicable, cuts can be taken from both sides. See also **Saw cuts**, **Cutting with big diameter blades**, and **Pre cut blade**.

Flush cutting flange The Pentrunder can be equipped with a special flush cutting flange where the blade is clamped using six countersunk screws, without a separate outer collar. See page 14 and 15.

Flush cutting Flush cutting is a method used for cutting flush with an adjacent surface, for example a floor, a wall or a ceiling. Chiselling becomes unnecessary. Flush cutting is a questionable method from a safety point of view. All safety precautions described on page 14 and 15 must be respected to minimise the risk involved with using this technique. As flush cutting requires use of a "half" blade guard, the operator should be aware that the level of safety never can be comparable to normal cutting when a full blade guard can be used. This is a potentially dangerous method and should be treated likewise.

Ear protection Ear protection should always be worn by all persons working or staying in the proximity of the wall sawing machine. Without ear protection the sound levels generated from the cutting process can be sufficiently high to cause lasting damages on the human ear.

Emergency stop button The Pentpak 15 is equipped with 2 emergency stop buttons, one on the remote control unit, and one on the power pack front panel. By depressing at least one of the emergency stop buttons, all functions will be reset. No functions will remain and the power pack must be restarted after the emergency stop button is released.

The blade, if in rotation, and in a cut, will continue to rotate because of its inertia, but will coast to a stop after a few seconds. If the blade is rotating and not in a cut, it will take longer before the blade stops.

Feed Feeding the blade in to the concrete is done by rotating the saw arm. This movement is controlled via the remote control unit by turning a switch in one or the other direction. The speed with which the arm will rotate is controlled by the potentiometer on the remote control unit. Adjust the in-feed speed so that a smooth cutting action is achieved. If the in-feed is jerky the blade will not cut a straight cut. See also **Depth of cut**.

Feed and travel regulation The feed and travel regulation features a semi-automatic control which senses differences in type of concrete, the blades ability to cut the concrete in question, and re-bars. A fairly constant power application is ensured by a special valve, which senses the working pressure to the blade motor and regulates the feed or travel motors until the system is in balance and an even power application is achieved.

The maximum level of power application can be set to suit a certain condition or type of blade, power supply etc., by adjusting the screw at the bottom right corner of the Pentpak 15. Insert a 6 mm Allen key into the hole in the front panel to do this adjustment and unscrew to decrease maximum working pressure and tighten to increase. The screw is set at $\frac{3}{4}$ turn out from bottom at the factory. This setting represents the correct setting for

achieving maximum performance with max output from the electric motor.

Freezing The Pentpak 15 is provided with a high efficiency water cooled electric motor and a water cooled oil cooler to control temperatures. The couplings on the power pack are therefore open when disconnected so that the water is automatically drained when the couplings are removed.

Important! *The water couplings must never be changed for a type with self sealing valves when the hose is disconnected. The water must always be free to drain out of the cooling jacket around the electric motor. Leaving water in the power pack will destroy these components in sub zero temperatures.*

If the power pack is started after components are destroyed by freezing, water may enter the electrical cabinet and cause damage to equipment located in this compartment.

Gearbox, 2-speed. The Pentruder 6-10 is equipped with a 2-speed gearbox to provide a simple means for adjusting the peripheral cutting speed to the actual blade diameter. By use of mechanical reduction gear, rather than a hydraulic oil-flow/speed reduction, performance is improved considerably. Safety is also better as once set, the speed can not be altered while the machine is running. It is less likely that a blade is run at a too high, and potentially dangerous, speed. Four spindle speeds are available, 560, 800, 1000 and 1260 rpm. See table on page 17 for correct settings of the peripheral cutting speed.

Gearshift The gears are shifted, or selected rather, by turning the knob next to the female hydraulic coupling on the saw head to the desired position. The knob must be depressed before it is turned. Rotate the blade slightly to engage the desired position and release the knob. Please note that the gear selection position is indicated by a digit on the knob, and a line on the fixed part, the line pointing **outwards** seen from the hydraulic motor housing.

Warning! *The gears may not be shifted before the two $\frac{3}{4}$ " hoses are disconnected from the saw. This rule must always be followed to eliminate that the blade motor is started by accident*

when the operator is working on the saw head. Failure to follow this instruction may result in serious personal injury or death.

Hoses, extension As far as is possible the hoses should not be extended to avoid pressure drop and power losses. If the hoses must be extended we recommend a maximum total length of 30 m from power pack to saw head. After the extension hoses have been connected the power pack should be left running for a minute operating the movements and starting the blade motor. Then check the oil level and top up if necessary. The oil level should be 1/3 up on the oil level indicator. See also **Pressure drop** and **Shutting of the blade motor**.

Lifting The Pentpak is not provided with hooks for lifting. Should this unit need to be lifted with a crane, this should only be done after permission and instructions have been given by a person responsible for safety on the site.

Oil change in the power pack The Pentpak 15 uses a very small amount of oil to reduce bulk and weight. It is therefore necessary to renew the oil at regular intervals. Control the oil level every time the power pack is used and top up if necessary. On the 76 mm level indicator the oil should be up to 1/3 of the glass when the power pack is switched off. With the new 127 mm level indicator the oil should be up to 2/3 of the glass when the power pack is switched off.

To change oil, or rather to renew the oil, unscrew the black filler cap and the filter cap. Then unscrew the plug in front of the left wheel and drain the oil.

Take out the oil filter and replace with a new cartridge.

Fill again with approximately 7 litres of hydraulic oil, quality HLP 46 or equivalent, until the level is 1/2 up on the 76 mm level indicator (2/3 up on the 127 mm level indicator) Wait for a few minutes until the level has equalised between the two tanks and fit the black filler cap. Now fill the filter tank completely and fit and tighten the filter cap.

Important! Do not start the power pack when oil level is low, and never with the oil filter cap removed.

Warning! No service or maintenance may be performed on the power pack unless it is disconnected electrically from the mains.

Start the power pack and let it run for approximately 10 seconds and shut it off again. Control the oil level and top up if necessary. On the 76 mm level indicator the oil should be up to 1/3 of the glass when the power pack is switched off. With the new 127 mm level indicator the oil should be up to 2/3 of the glass when the power pack is switched off.

Oil change in the power pack gear transmission. The Pentpak 15 uses a gear transmission to transmit power from the electric motor to the pumps. This transmission is located under the bottom plate of the power pack and is contained in a oval housing, visible if the power pack is tilted backwards.

The oil should be changed regularly every twelve months to prevent excess wear and the build up of harmful condensation. To change oil, unscrew the oil-plug and drain the housing completely. Refill with 0.3 L of gearbox oil, preferably synthetic oil with 75W viscosity. Clean the magnetic plug, fit it and tighten again.

Oil change in the saw head transmission The Pentrunder 6 – 10 is equipped with a 2-speed mechanical gearbox which is lubricated separately by oil. The oil must be changed regularly, every 6 months, to avoid premature wear and to avoid negative effects from condensation. To change oil, unscrew the oil-plug and drain the arm completely. Refill with 0.4 L of gearbox oil, preferably synthetic oil with 75W viscosity. Clean the magnetic plug, fit it and tighten again.

Oil cooler The Pentpak 15 is equipped with an efficient water cooled oil cooler to keep the oil temperature on a healthy level. At least 10 litres of cool water is required to keep the temperature down when maximum power is used. Less water is required for less demanding jobs. The oil cooler is automatically drained from water as soon as

both water couplings are disconnected from the power pack.

Please observe that the water supply must always be connected to the lower connection, and the water running up to the saw to the upper connection.

Oil filter The Pentpak 15 is fitted with a 10 micron oil filter which filters all oil coming back through the hoses. As the Pentruder and the Pentpak uses a very small amount of oil, about 17 litres totally, in the whole system, it is of greatest importance that the filter is replaced twice annually. New filters can be ordered from your dealer using Part. No. 60 13 01 00.

Oil leak After many hundred hours of service it may occur that seals in the saw head and in hoses, couplings or the power pack may start to leak. If so, please contact your dealer for immediate service.

Oil level Control the oil level every time the power pack is used and top up if necessary. On the 76 mm level indicator the oil should be up to 1/3 of the glass when the power pack is switched off. With the new 127 mm level indicator the oil should be up to 2/3 of the glass when the power pack is switched off and the oil is cold. Under operation the oil level may seem to be lower. This is normal and not an indication that something is wrong.

If the oil level is allowed to become too low, then the pump which supplies the feed and travel movements with oil is the first one to suffer from oil starvation. If these movements are jerky and inconsistent, it is a clear indication that there is too little oil in the system.

The main pump supplying oil to the blade motor is the last pump to suffer and is therefore unlikely to be damaged, even after several minutes of running with too little oil in the tank. Stop the power pack and check for visible oil leaks. If you find any, contact your dealer for service, otherwise, top up with oil and try again. See also **Oil change**.

Oil vent To reduce the weight and dimensions of the power pack, the Pentpak 15

uses a very small amount of oil. Consequently, there is no big oil tank to take care of air bubbles and let them slowly rise to the surface and disappear. In the Pentpak 15 the problem with air bubbles is instead eliminated by use of a special "turbo charger" which feeds the main pump with pressurised oil. The result is that much less air bubbles are produced and there is no need for a big oil tank.

Overload clutch The Pentruder 6 -16 is provided with 3 overload clutches. First there is an overload clutch on the spindle.

This device is incorporated in the design to safeguard the level of security needed when a flush cutting blade is used, and if the transmission fails in some way. This clutch will disconnect the spindle from the transmission and allow the blade to coast freely to stop in case the transmission is blocked for some reason.

One reason for the transmission to be blocked could be if the user neglects the specified maintenance intervals, and allows, for example, the machine to run with an insufficient amount of oil in the transmission housing. This will inevitably cause the transmission to either wear out or simply seize up.

Without an overload clutch, the inertia of the blade could shear off the screws that clamps it to the flush cutting flange and the spindle. It is therefore very important that the correct 10.9 quality screws are used and that they are properly tightened to the specified torque using a torque wrench.

The second and third overload clutches are designed to allow the feed and travel mechanisms to be released if a blade is jammed instantaneously in a cut. When this happens, the blade starts to rotate around a different centre of rotation, and in certain unfavourable positions, the force on the spindle, resulting from the dissipation of energy stored in the blade (inertia load), could wreck the travel and feed transmissions. With the overload clutches these transmissions will allow the saw arm and carriage to move in the direction the forces will try to move them, and these members will automatically be

positioned to absorb the energy in a less harmful way, than without the clutches.

Such sudden and instant overload situations are very rare, but the Pentrunder is designed to take care of the situation. If any of the overload clutches have been released, a trained mechanic can repair the coupling by replacing the shear pin, but we recommend that the machine is brought to your dealer for service.

Pre cut and pre cutting blade Whenever deep cuts must be taken, it is feasible to first use a pre cutting blade. A pre cutting blade is wider and stiffer than a normal blade and will provide the stability which is required to make a perfectly straight and clean cut, reducing friction against the sides of the cut for the subsequent bigger blades. For deep cuts it is of greatest importance that the first cuts are taken with reduced power application to allow the blade to cut freely and straight, without being distorted by too high cutting forces. See also **Saw Cuts**.

Pressure drop To avoid unnecessary power losses the system should be run with as short hoses as possible. The standard equipment contains 8 m long hoses and provide low pressure drop and excellent efficiency.

Quick disconnect couplings Quick disconnect couplings are used to simplify connection and disconnection of mechanical, electrical or hydraulic devices. The Pentrunder and Pentpak uses all of them and utilises only proven systems for highest safety. For the hydraulic main flow $\frac{3}{4}$ " couplings are used and for the secondary flows, the movements, $\frac{1}{4}$ " couplings are used. For water $\frac{1}{4}$ " and $\frac{3}{8}$ " couplings are used. For electrical connection between the power pack and the remote control unit, high quality multi-pin connector are used.

Rapid traverse The Pentrunder 6 – 10 has, when powered by the Pentpak 15, a rapid traverse of 2.2 m / minute along the track and 2 full revolutions / minute for the saw arm. The speed of arm rotation (feed) and travel along the track is primarily regulated by adjusting the potentiometer on the remote control unit. If the potentiometer is turned clockwise the speed will increase and vice versa. Due to the low friction motors and transmissions used on

this machine, the travel and feed movements may not come to a complete stop even if the potentiometer is turned fully anti clockwise. To stop completely the directional valves must then be returned to their neutral position.

Remote control, extension of cable The cable for the remote control unit can be extended by using 10 m extension cables. A maximum of 2 extension cables may be used.

Remote control unit The Pentrunder 6 - 10 is easily controlled by means of a hand held remote control unit where all functions are gathered. This solution enhances safety as the operator can have a full and unrestricted overview and control of the machine.

The remote control unit is connected to the Pentpak 15 power pack with a multi-pin connector. All functions are reset as soon as at least one of the phases of the power supply is disconnected, or as soon as at least one of the emergency stop buttons are depressed. No functions remain and the power pack must be restarted after a stop is caused by any of the above mentioned reasons.

Thermal protection relay The Pentpak 15 is equipped with a special thermal protection relay to protect the electric motor from overheating and damage to the electric motor. The temperature of the electric motor can rise to a dangerous level if too little cooling water is run through the system. It can also happen that too warm or dirty water is run through the system, which will reduce the cooling capacity. A special relay therefore monitors the temperature of the electric motor windings and shuts down all functions when the temperature has risen over the allowed value. The thermal temperature relay can only be reset by removing the 63 Amp plug from the power pack. If the relay has shut down the power pack, do not shut off the cooling water, but let it continue to flow to cool the motor down to a healthy temperature again.

Track The track is the device used for holding and guiding the saw head along the cut. One track should be fastened to the wall with at least two track feet, more if the conditions for fastening is unfavourable.

Track feet The track feet have the function to fasten the track or tracks to the surface which

is to be cut. Each track foot must be fastened with at least M12 screws of quality 10.9 or better, using thick washers under each screw head. Preferably drop anchors type HKD M12 or equivalent should be used, or expansion bolts of minimum M12 size. If drop anchors or expansion bolts can not be used, through bolts with nuts and large washers should be used to achieve satisfactory safety.

Transportation of the power pack

Whenever the power pack is transported in a vehicle, it is important that it is securely strapped down and well protected. The power pack should preferably be transported standing on its wheel and foot, but can be laid down resting on its handles. We can not guarantee that no oil leaks out but generally there is no problem.

Transport, wheels The Pentpak 15 is equipped with two wheels for transportation. The tyre pressure should be 2 bar / cm².

Travel The saw head is propelled along the track by means of a hydraulic motor, in turn controlled by directional valve and a proportional flow (speed) valve, operated by a switch and a potentiometer on the remote control unit. Adjust the speed of travel by turning the potentiometer. Try to achieve smooth cutting and avoid a jerky movement along the track. A smooth travelling speed ensures the cut will be straight and precise. If

the travel speed is pushing the blade too hard, the blade will give and it can not cut straight.

Water cooled electric motor The Pentruder is equipped with a very efficient and powerful electric motor, which in spite of its small dimensions can deliver 15 kW output without being damaged or overloaded. This is possible only because of a specially designed water cooling system which controls the temperature of the electric motor and eliminates any hot spots on the motor.

Water cooled electric motor The Pentpak 15 is equipped with a special high efficiency electric motor for highest output at lowest possible power consumption. In spite of its diminutive dimensions, the electric motor maintains a very high efficiency even under maximum output. This is possible only

because of adoption of a specially designed cooling system the motor.

Water cooling of the saw blade The saw blade is cooled by the same water which first is used to cool the electric motor and the hydraulic oil. The water is fed through the power pack and then to the hose and on to the sawhead. In the saw arm there is a swivel to feed the water into the centre of the spindle and further to both sides of the blade flange.

The swivel is provided with 3 seals. One seal is to seal off oil in the saw arm transmission. Two seals seal off the water which is fed through the spindle quick disconnect screw, and on through the pull stud at the front of the spindle. Besides the Screw there is a small hole. If water comes out of that hole while the water is switched on, this is an indication that the seals must be replaced.

Please contact your dealer for service. The swivel should be checked every day. If the seals are not replaced in time, water may enter the saw arm transmission and gearbox, which may cause the transmission to seize or cause irreparable damages.

Water swivel See "Water cooling of the saw blade".

MAINTENANCE

For the Pentruder 6- 10 / Pentpak 15 to remain in a condition which is safe for operation at all times, certain maintenance is needed. Please read the instructions below carefully before any service work is commenced.

For safe and uninterrupted operation of the machine, we strongly recommend that the complete machine is brought back to your dealer for service once a year. At this service the machine is checked for proper function and all components critical for safe and reliable operation are checked and replaced if necessary.

Please respect the following maintenance instructions:

Warning! No service or maintenance may be performed on the power pack unless it is disconnected electrically from the mains.

Warning! No service or maintenance may be performed on the saw head unless it is disconnected hydraulically from the power pack.

Bolts for flush cutting blades:

Always replace worn or damaged bolts with new of the correct length and quality. See "**Bolts for flush**"... in the **Wordlist** for further information.

Cleaning:

The machine should be carefully cleaned and all functions checked and be found normal before use of the machine.

Hoses:

Check that all hoses are the correct type, R2 for the main ¾" hoses, and that they are in faultless condition.

Guide rollers:

Check that the guide rollers on the saw head can move freely without too much friction. A certain amount of friction is always present as the bearings are double sealed with both rubber and steel scraper seals.

Oil change in the power pack:

Renew the oil at regular intervals, preferably every two months. To renew the oil, unscrew the black filler cap and the filter cap. Then unscrew the plug in front of the left wheel and drain the oil. Take out the oil filter and replace with a new cartridge.

Fill again with approximately 5 litres of hydraulic oil, quality HLP 46 or equivalent, until the level is 2/3rd up on the level indicator. Wait for a few minutes until the level has equalised between the two tanks and fit the black filler cap. Now fill the filter tank completely and fit and tighten the filter cap.

Important! Do not start the power pack when oil level is low, and never with the oil filter cap removed.

Start the power pack and let it run for approximately 10 seconds and shut it off again. Control the oil level and top up if necessary. The oil level should be 2/3 up on the oil level indicator with cold oil and power pack switched off.

Oil change in the power

- p. gear transmission:** To change oil, clean the area around the plug, and the plug itself. Unscrew the oil-plug and drain the housing completely. Tilt the power pack backwards on its handles and fill up to the plug hole with Red Line 75W140 high performance synthetic gearbox oil. Clean the magnetic plug, fit it and tighten again. Oil should be changed three times per year or every 100 hours.
- Oil change in the saw head transmission:** To change oil, clean the area around the plug, and the plug itself. Unscrew the oil-plug and drain the arm completely. Refill with Red Line 75W140 high performance synthetic gearbox oil. Clean the magnetic plug, fit it and tighten again. Oil should be changed six times per year or every 50 hours.
- Oil filter:** New filters can be ordered from your dealer using Part. No. 60 13 01 00.
- Oil level:** Control the oil level every time the power pack is used and top up if necessary. The oil level should be 2/3 up on the oil level indicator with cold oil and power pack switched off. Under operation the oil level may seem to be lower. This is normal and not an indication that something is wrong.
- Arm overload clutch:** If the overload arm rotation slip clutch is worn and the saw arm slips, the machine should be brought to your dealer for service. See “**Overload clutch**” in the **Wordlist**
- Quick disconnect hydraulic couplings:** Check all couplings for proper function and replace when necessary.
- Quick disconnect coupling for the saw blade:** The flange and the spindle are provided with drive dogs to transmit the torque to the blade and centering cone to align the flange to the spindle. Clean the dogs and the cone regularly to allow the flange to always be aligned and properly in mesh.
- Remote Control unit:** Check the remote control unit for correct function and that the multi-pin-plug is free from dirt and undamaged. Clean out any moisture inside the remote control box.
- Transport wheels:** Correct tyre pressure is 2 bar / cm².

Technical data Pentruder 6 - 10

Saw blade diameter max.:	1.200 mm
Max cutting depth with 1200 blade:	515 mm (Blade radius minus 85 mm)
Saw blade arbor diameter:	60 mm
Saw blade motor:	Gear type
Max output power:	10 kw
Max output torque:	100 Nm (1:st gear)
Spindle speed under load:	1:st gear 850 rpm 2:nd gear 1250 rpm
Travel:	Hydraulic motor
Feed:	Hydraulic motor
Water feed:	Central through the blade flanges
Blade flange diameter:	158 mm
Bolt circle diameter for flush cutting:	130 mm 6x M 8 10.9 countersunk screw 110 mm 6x M 10 10.9 countersunk screw 108 mm 6x M 10 10.9 countersunk screw
Weight:	18.5 kg

Track system

Track feet:	Universal aluminium and steel
Weight:	2.0 kg
Track 1.15 m, weight:	7.7 kg
Track 2.0 m, weight:	13.4 kg
Track 2.32 m, weight:	15.6 kg

Technical data Pentpak 15 hydraulic power pack

Electric motor:	Water cooled, self draining
Electric output power:	15 kW
Power supply:	The power pack should be connected to a 5-pin 400 V 3-phase supply with minimum 16 Amp fuses.
Current idling:	9 Amp
Current at 8 kW output:	16 Amp
Current at 15 kW output:	30 Amp
Starting apparatus:	Automatic Star-Delta starter
Oil flow main circuit:	Approximately 42 L/min
Working pressure:	Max 175 bar
Oil tank volume:	5 L
Secondary oil flow: (Movements)	6 L/min
Oil filter:	10 micron absolute
Height:	500 mm
Width:	315 mm + wheels
Depth:	415 mm
Weight:	102 kg

EC-declaration of conformity

We, **Tractive AB** declare that the machine

Manufacturer: Tractive AB
Alderbäcken 35
78193 Borlänge
Sweden

Category: Hydraulic Power Pack
Make: Pentpak
Type: PP 15

- Is in conformity with the provisions of the Machinery Directive 98/37/EC.
- Is in conformity with the provisions of the following other EC-directives:
Low Voltage Directive 73/23/EEC (amended by 93/68/EEC)
EMC-Directive 89/336/EEC (amended by 92/31/EEC and 93/68/EEC).

We also declare that it is in conformity with directive 2000/14/EC, measured in accordance to the Conformity Evaluation Method set out in Annex VI para.5 and evaluated during production as in Annex VI para.6, ^{2nd} procedure.

Notified Body: 0404 SMP Svensk Maskinprovning AB
Fyrisborgsgatan 3
75450 Uppsala
Sweden

Noise related value: 15 kW

Measured sound power level: L_{wa} : 97 dB(A)

Guaranteed sound power level: L_{wa} : 104 dB(A)

Aldbäcken, Borlänge 23 September 2002



Anders Johnsen

Technical Director

EC-declaration of conformity

We, **Tractive AB** declare that the machine

Manufacturer: Tractive AB
Alderbäcken 35
78193 Borlänge
Sweden

Category: Hydraulic Wall Saw

Make: Pentruder

Type: 6-10

- Is in conformity with the provisions of the Machinery Directive 98/37/EC.
- Is in conformity with the provisions of the following other EC-directives:
Low Voltage Directive 73/23/EEC (amended by 93/68/EEC)
EMC-Directive 89/336/EEC (amended by 92/31/EEC and 93/68/EEC).

Aldbäcken, Borlänge 23 September 2002



Anders Johnsen

Technical Director